

QTY

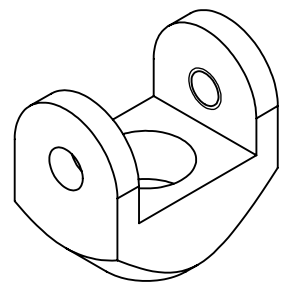

FINISH: ANODIZED	DEBUR AND BREAK SHARP EDGES	DO NOT SCALE DRAWING	REVISION: A
----------------------------	-----------------------------------	----------------------	--------------------

TITLE:
FUEL RAIL CLEVIS

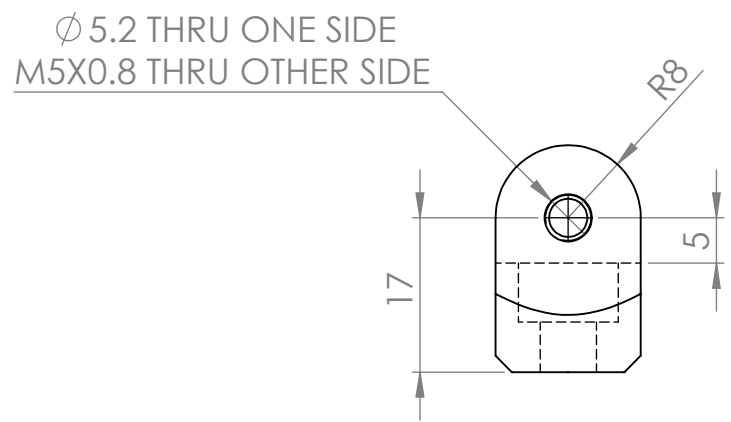
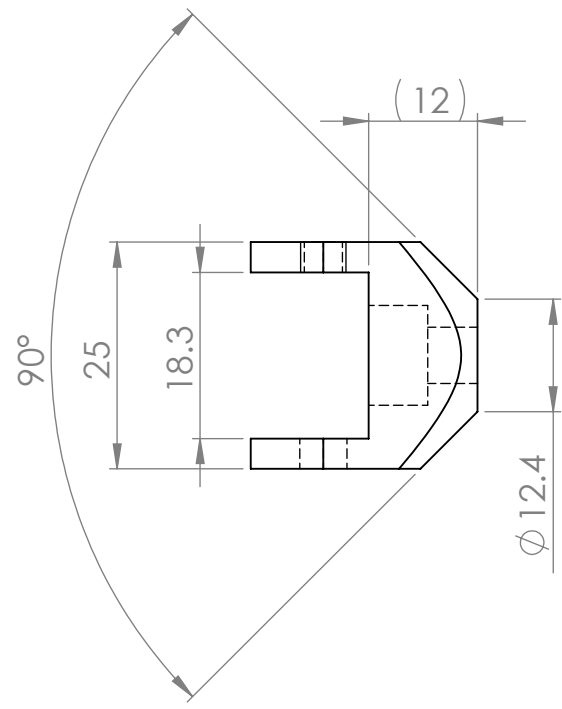
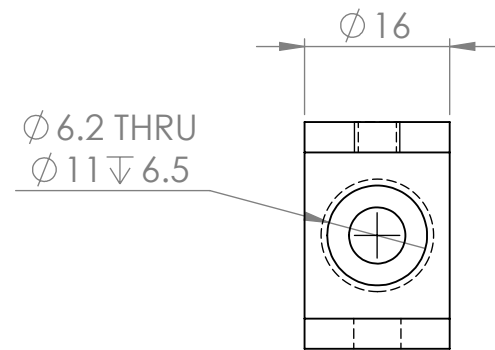

UNLESS OTHERWISE SPECIFIED:
 DIMENSIONS ARE IN MILLIMETERS
 WHOLE DIMENSIONS ± 0.50
 ONE DECIMAL PLACE ± 0.25
 TWO DECIMAL PLACES ± 0.10
 ANGLES $\pm 30^\circ$

7 Monomeeth Drive
 Mitcham, Victoria 3132
 Ph: (03) 9873 5177

	NAME	SIGNATURE	DATE	MATERIAL: ALUM 6061	DWG/PART NO. 825-010	A4
DRAWN	BJM		8/10/15			
CHK'D						
APPV'D				WEIGHT:	SCALE:	SHEET 1 OF 1