

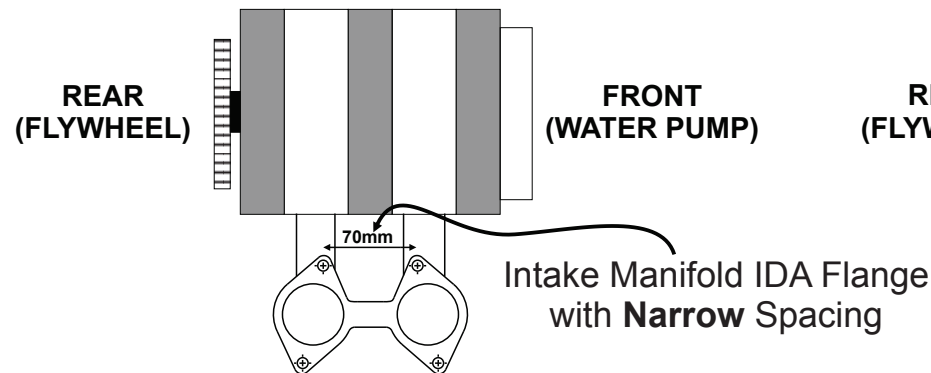

Aftermarket Rotary Intake Manifolds to suit IDA style Throttle Bodies can be configured with the Flange Face having either "Narrow" or "Wide" configuration as in the diagrams below.

It is vitally important that you understand how your manifold is configured so you can tell us before we finalize your IDA throttle body. This information allows us to set the correct throttle opening rotation, TPS location and Throttle Cable Mounting location.

ROTARY ENGINE VIEWED FROM ABOVE



NARROW SPACING TYPE

ROTARY ENGINE VIEWED FROM ABOVE

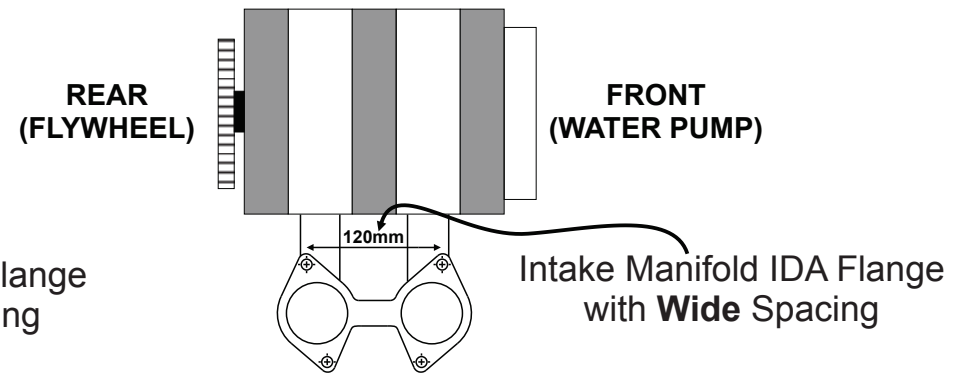

WIDE SPACING TYPE